



Note Dispenser
NDE1000
Installation Guide



Use of Materials Limitations

International Currency Technologies Corporation (ICT) all rights reserved.

All materials contained are the copyrighted property of ICT.

All trademarks, service marks, and trade names are proprietary to ICT.

ICT reserves the right at all times to disclose or to modify any information as ICT deems necessary to satisfy any applicable law, regulation, legal process or governmental request, or to edit, refuse to post or to remove any information or materials, in whole or in part, in ICT's sole discretion.

Contents

1. Introduction	
1-1. Overview	2
1-2. Features	2
2. Specifications	3
3. Packing List	3
4. Dimension	4
5. Installation	
5-1. Harness Application	7
5-1-1. I/O Circuit	11
5-2. Key Function	12
5-3. DIP Switch Setting	13
5-4. Software Download and Upgrade	
5-4-1. ICT FP-004 Programmer Firmware Upgrade ...	13
5-4-2. USB Pen Drive Firmware Upgrade	14
5-4-3. ICT MTB Firmware Upgrade	15
6. Operation	
6-1. Unusable Note	17
6-2. How to Fill Notes	19
6-3. Low Level Adjustment	20
7. Maintenance	21
8. Troubleshooting	
8-1. Errors Messages	22

1. Introduction

1-1. Overview

NDE1000, a compact size with up to 1000 banknotes capacity, is designed able to dispense versatile notes released from worldwide countries via a built-in study mode.

With LCM display and operation key-pad, NDE1000 is very easy to use for the user no matter on settings, operations or troubleshooting.

1-2. Features

- A wide-range voltage power-input
- Identify and dispense worldwide currencies through a built-in study mode
- Easy and convenient firmware download via USB pen drive
- Easy operation and settings via digital display with key pad
- Security lockable cashbox
- Compact design to save installation space

2. Specification

General

Dispensing Speed 2.5 notes per second

Interface RS232

Installation Indoor

Electrical

Power Source DC12~24V

Power Consumption DC 12 V- Standby: Approx. 0.1A,
Operation: Approx. 1.8A,
Maximum: Approx. ≤4.5A
DC 24 V- Standby: Approx. 0.1A,
Operation: Approx. 1A,
Maximum: Approx. ≤3.5A

Operation Environment Operation Temperature: 0°C~55°C
Storage Temperature: -30°C~70°C

Mechanical

Bill Capacity Approx. 800~1000
(depends on the note thickness)

Bill Accepted Width (W) 62~77 mm
(L) 120~160 mm
(T) 0.08~0.125 mm

Outline Dimension Refer to page.4

Weight Approx. 5kg

3. Packing List

Main Note Dispenser

Accessory Harnesses: Refer to page. 7
NDE1000 Installation Guide

4. Dimension

NDE-1000 (Standard)

NDE-1000 (JAE connector)

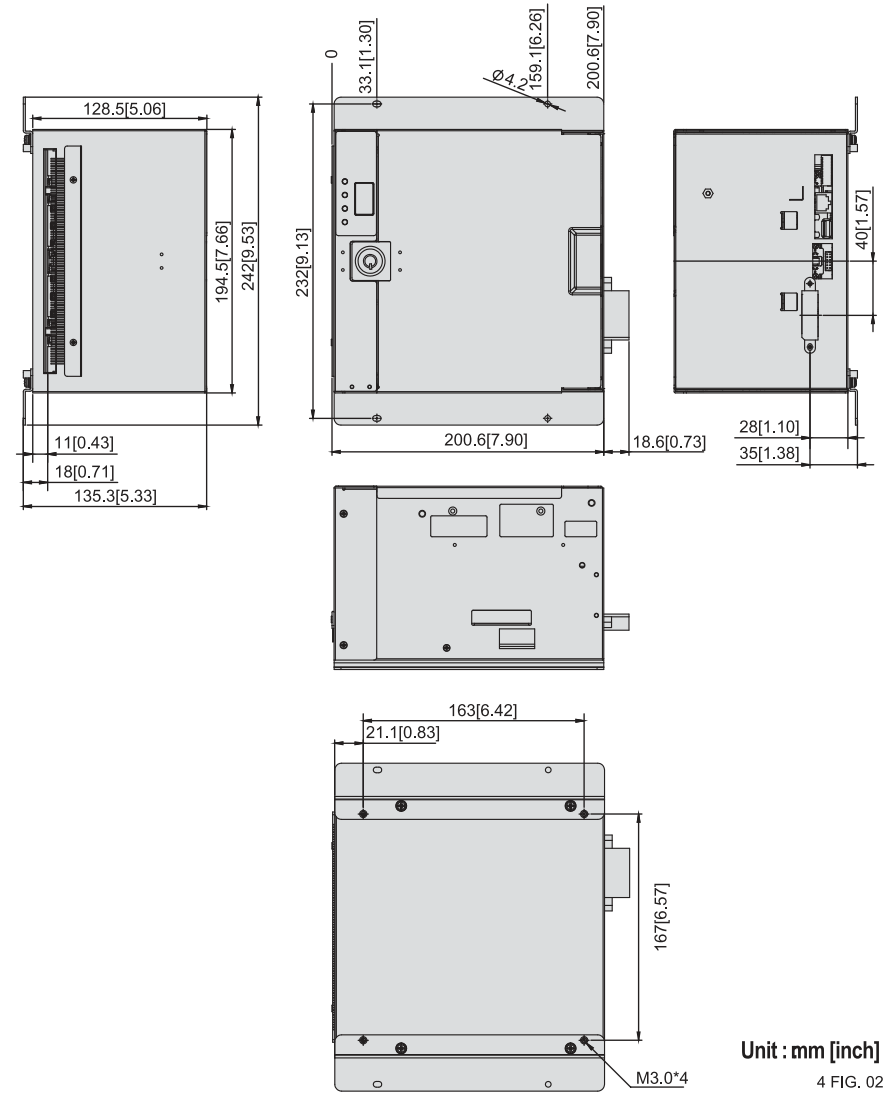
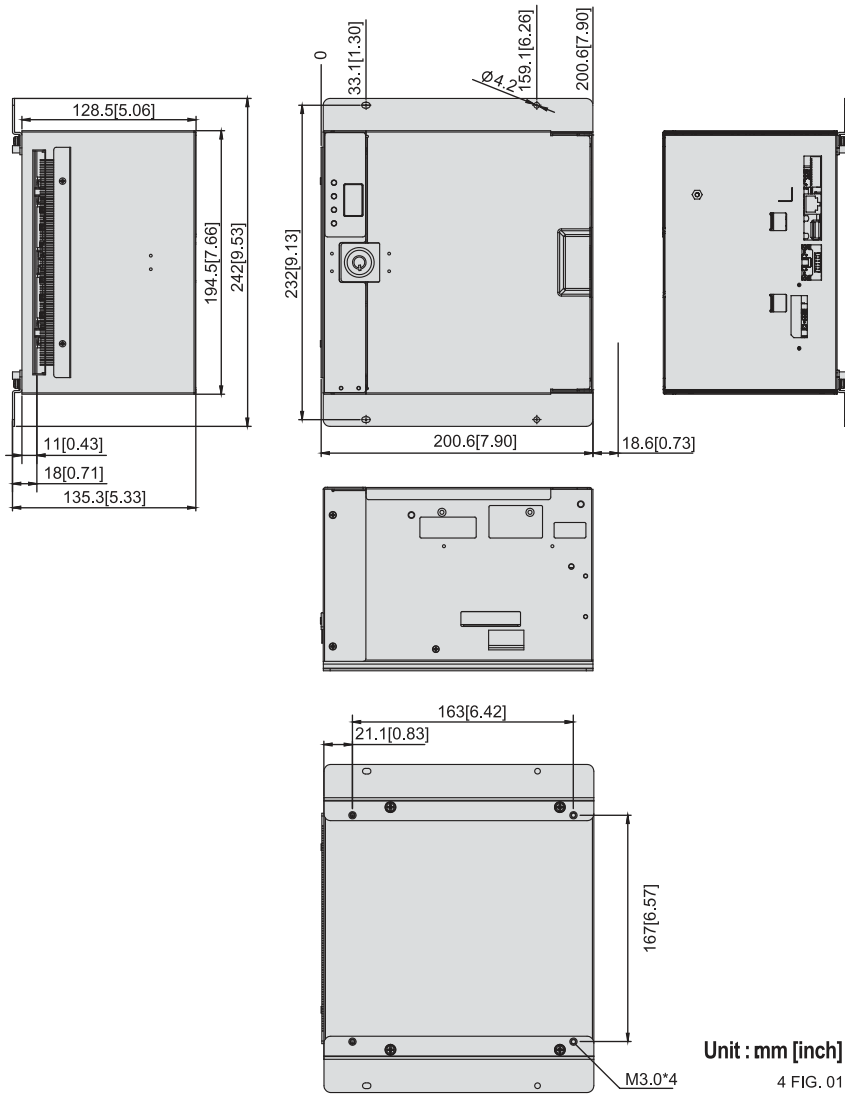



Please follow instructions below before installing NDE1000:
 [L]: the distance from the note mouth: 150mm or above.
 [L1]: the distance from NDE1000 bottom: 150mm or above.

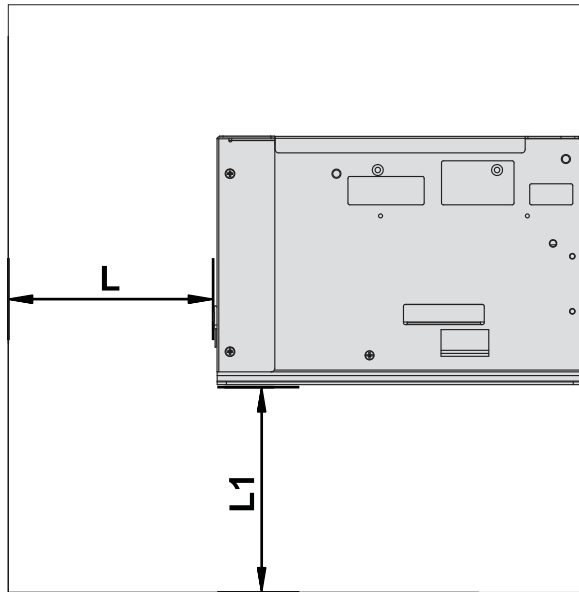

4 FIG. 03

5. Installation

5-1. Harness Application

5-1 TABLE 01

Interface	Used Voltage	Usage	Harness	Page
RS232	12~24V DC	Power	WEL-RBD10	7
RS232	12~24V DC	Power & *Data Comm.	WEL-RBD16	8
RS232	12~24V DC	Power & *Data Comm.	WEL-RBD33	9
RS232	12~24V DC	Power & *Data Comm.	WEL-RBD34	10

*Data Comm. : Data Communication.

5-1 FIG. 01

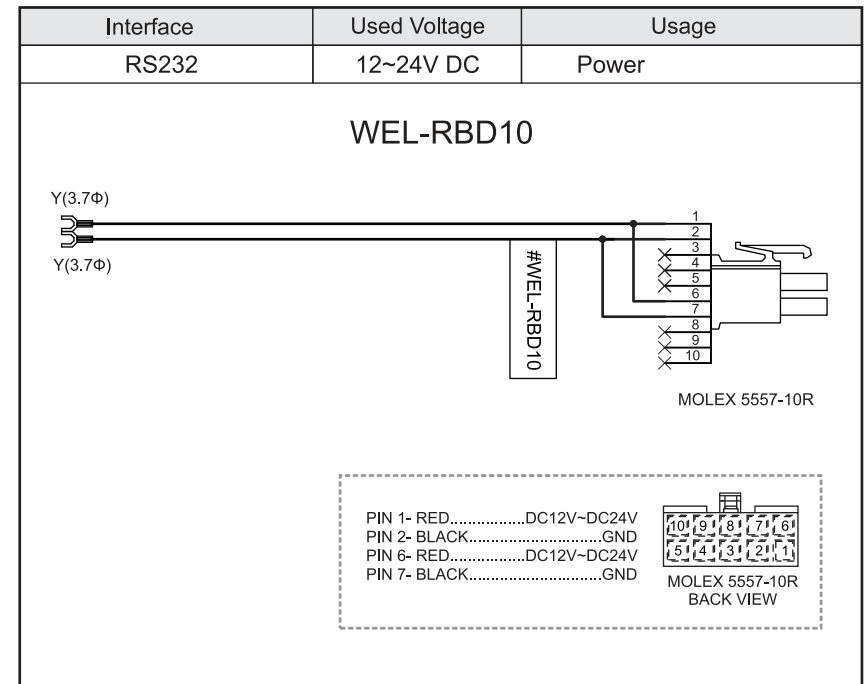

5-1 FIG. 02

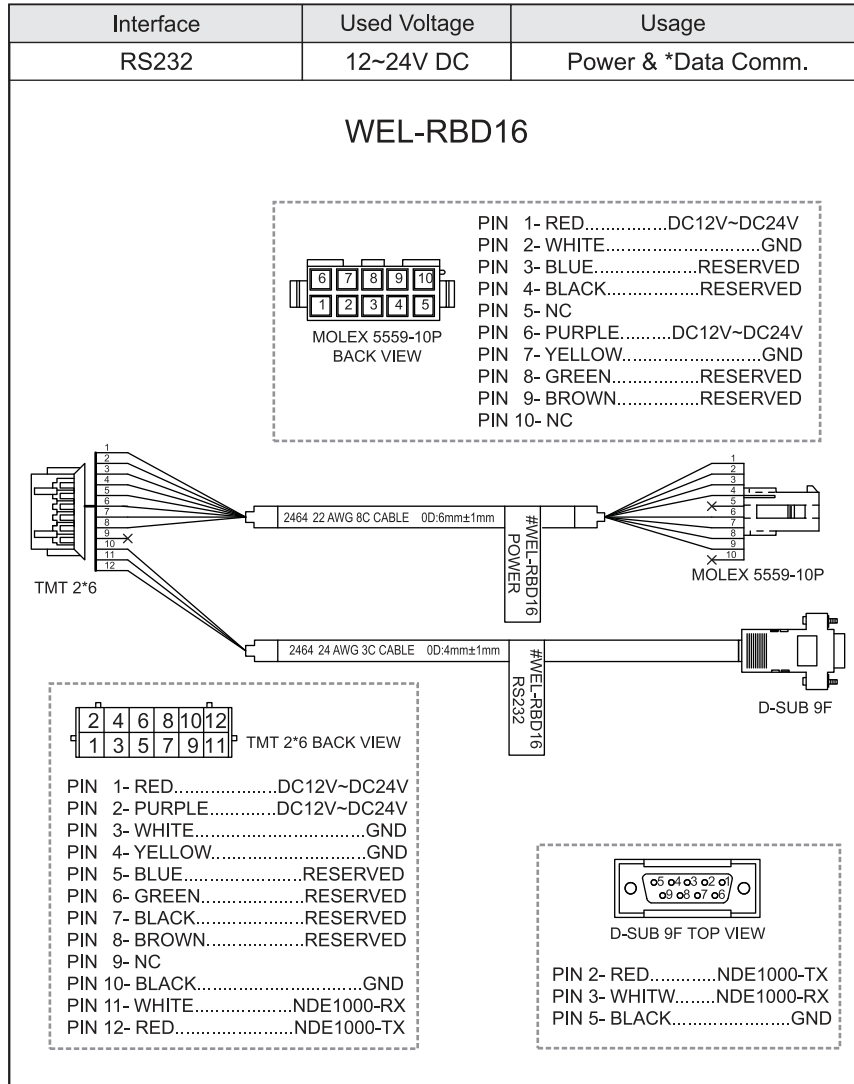

5-1 FIG. 03

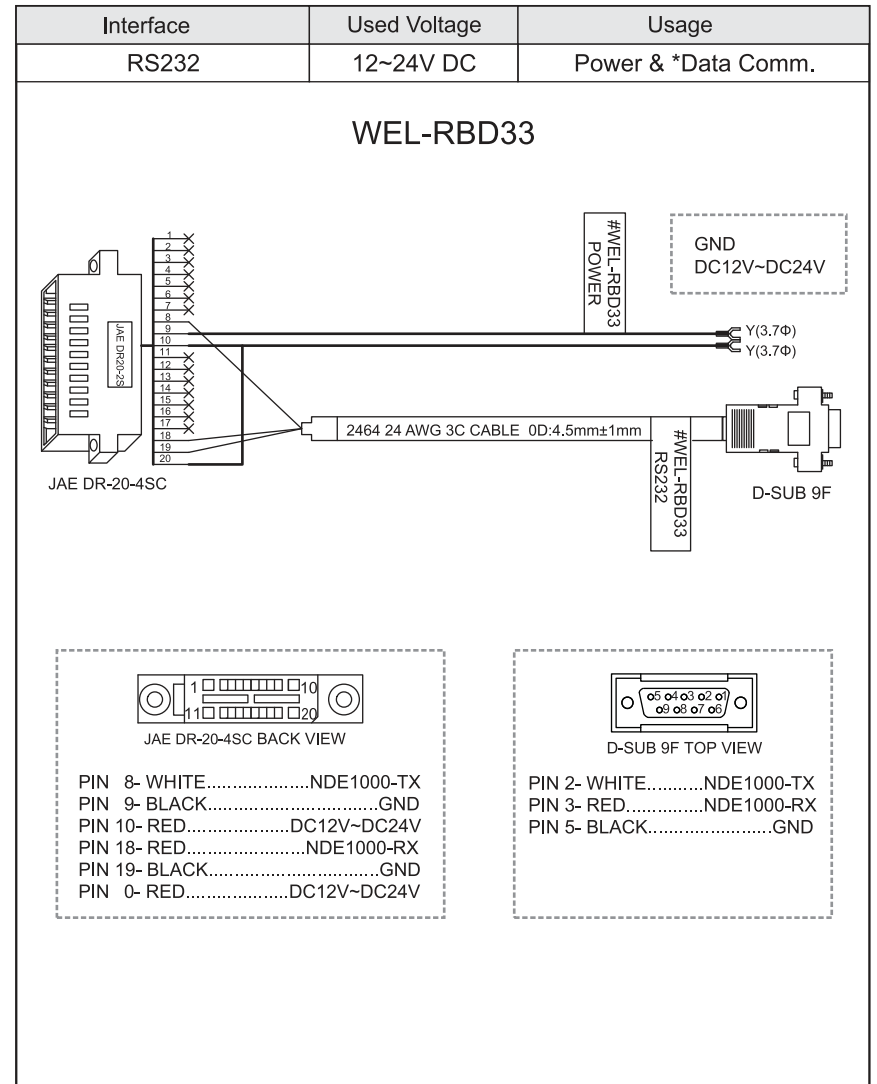

5-1 FIG. 04

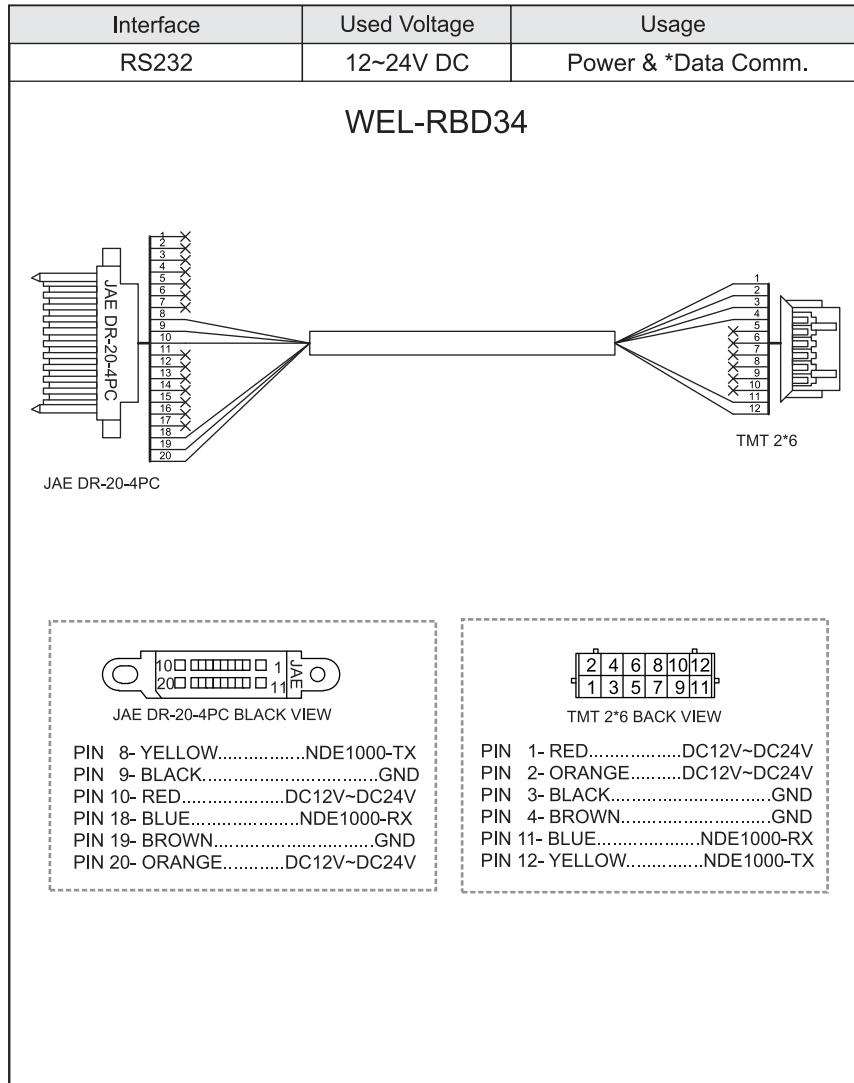

5-1-1. I/O Circuit

RS232 Interface.

5-1-1 FIG. 01

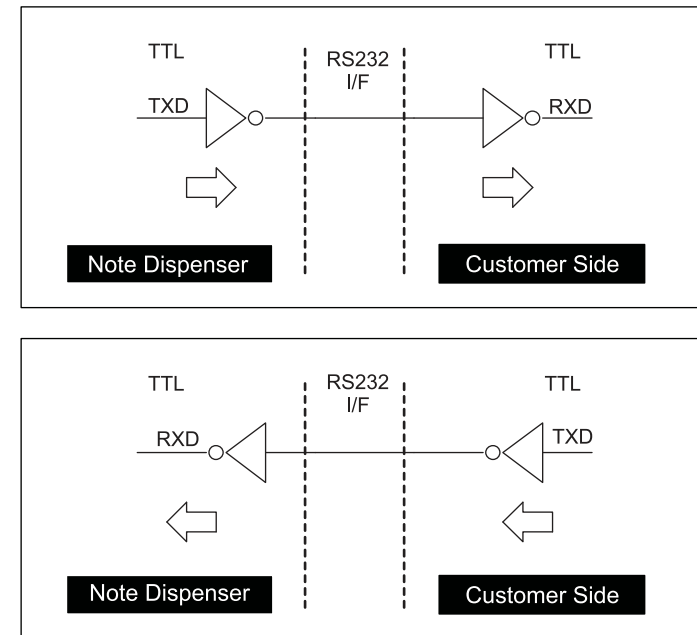

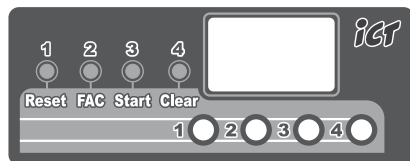

5-2. Key Function

Key Setting	Function
When the power is ON, the LED display shows Version No. for two seconds.(ex. 001~999) Pressing FAC Key 2 times	Enter into [Set up] Mode
Enter into [Set up] Mode Pressing FAC Key select item Pressing Start Key setting(+) Pressing Clear Key setting(-)	Enter into first Item ID number set up(ex.C00~C99) Enter into second Item: set up regular dispensing quantity (ex.E01~10). Enter into third Item set up: S Pressing Start Key , Save changed setup, and return to Standby Mode. Fourth Item set up: rc Pressing Start Key, Clear the warning of cleaning required.
Pressing FAC Key 3 seconds	Make sure there are at least 10 banknotes inside of NDE1000, and enter into [Learning] Mode (dispensing 10 notes) Return to Standby Mode when Learning finished.
Standby Mode Pressing Start Key 3 seconds	Regular dispensing
Standby Mode Pressing Clear Key 3 seconds	Clear the number of Non-automatic dispensed.
Pressing Reset and Clear Key	Reset NDE1000 / Escape [Set up] Mode.
After clearing of fault Pressing Clear Key 2 times	Clear error code

Display directions:

Display screen would show the number how many banknotes dispensed by manual Total three digits shown on the screen, digits, tens, hundreds.

It would show the point". in case of the number over 999

For example, "999." means 1999, "99.9" means 2999, "9.99" means 3999.

Please check the trouble shooting table when NDE1000 have any error occurred.

5-3. DIP Switch Setting

You can see a DIP-SW at the backside of NDE1000 for you to set up, for example, the interface, function settings, etc.
Please check the dip-switch setting manual for details.

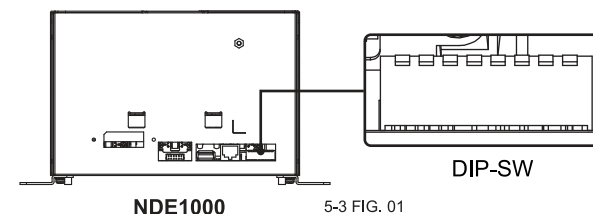

5-3 FIG. 01

5-4. Software Download and Upgrade

5-4-1. ICT FP-004 Programmer Firmware Upgrade

There are three ways to download and upgrade the software to NDE1000. Please contact ICT to purchase FP-004 and refer to FP-004 user guide for software upgrade information.

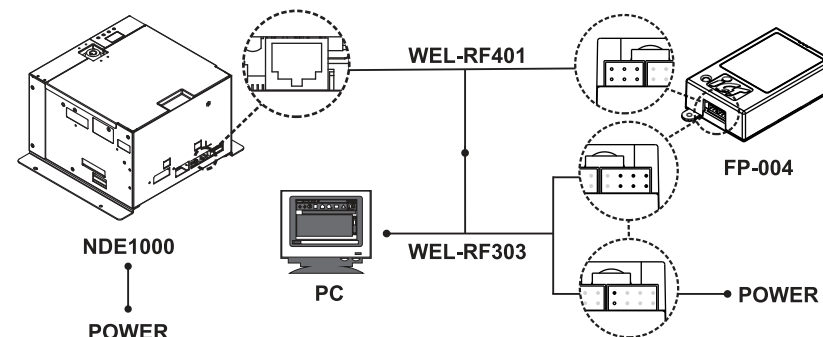

! Please turn off the power of NDE1000 before connecting the FP-004.

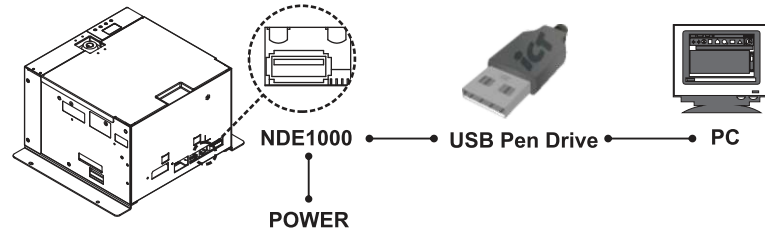

5-4-2. USB Pen Drive Firmware Upgrade



 Please turn off the power of NDE1000 before connecting the USB pen drive.

Step 1. Please load the software(NDEX#SXXXXIBBBBXXXXX.bin) into USB pen drive through PC.

Step 2. Turn on the power after connecting the USB pen drive to the USB Port of NDE1000.

Step 3. It shows from  turn to  means download finished.

Unplug USB pen drive and then NDE1000 will automatically back to standby mode.

5-4-3. ICT MTB Firmware Upgrade

Step 1. Turn on the power of MTB.

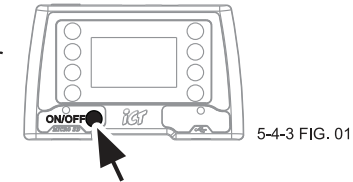

Step 2. Press the **bottom right button** till “Flash Drive mode” shown on the display.



Step 3. Press the **upper left button** to get into the Flash Drive mode.

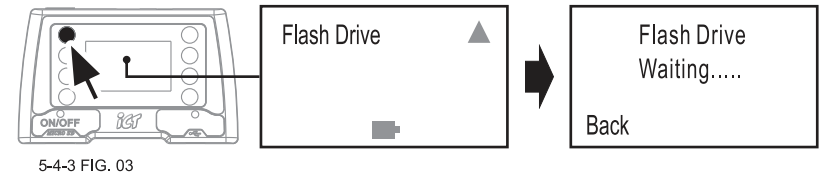

Step 4. Use the download cable WEL-RHP57 connecting to PC.

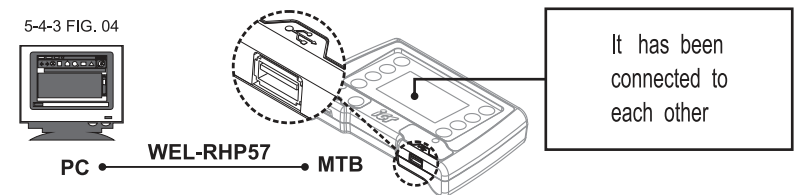

Step 5. Please load the software(NDEX#SXXXXIBBBBXXXXX.bin) into MTB through PC.

Step 6. Turn on the power after MTB is connected with NDE1000.

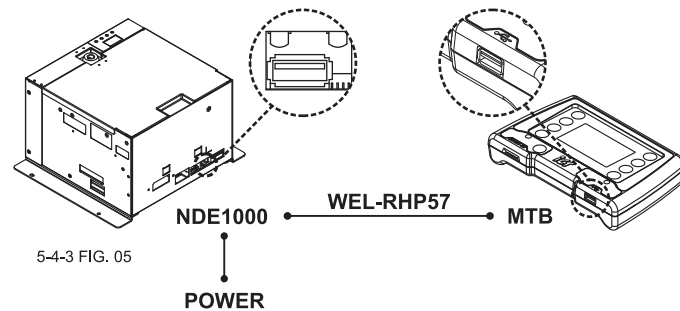

Please turn off the power of NDE1000 before connecting the MTB.

Step 7. It shows from to means the

download finished.

Unplug MTB and then NDE1000 will automatically back to standby mode.

6. Operation



6-1. Unusable Note

Mixing up different denominations or currencies may cause double banknotes output due to different banknote form and material. In addition, the following type of notes are prohibited.

6-1 TABLE. 01-1

Type	Diagram	Solution
Curled or wrinkled notes		Unfold the note
Broken notes		Prohibited

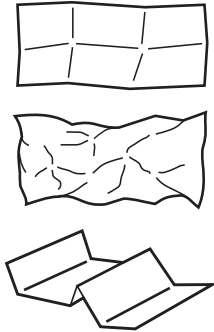
6-1 TABLE. 01-2

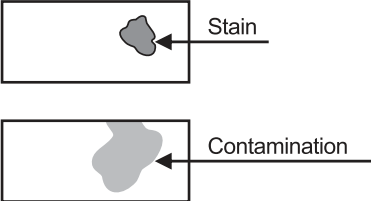
Type	Diagram	Solution
Curled or wrinkled notes		Prohibited
Taped notes		Prohibited
Dirty notes		Prohibited

6-2. How to Fill Notes

1. Open the upper cover, loosen a screw and take the fixing plate out.

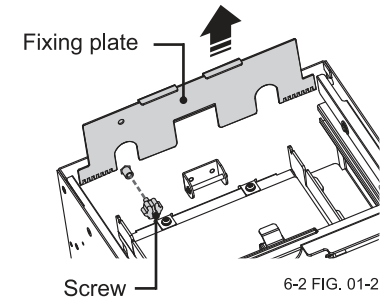
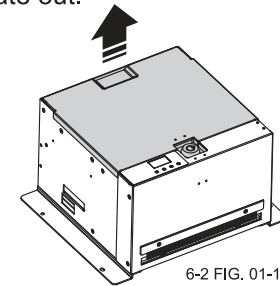

2. Move the plates to the both sides, and fix the banknote plate on the back side.

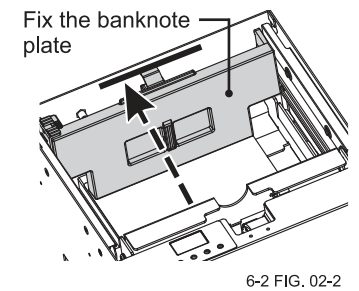
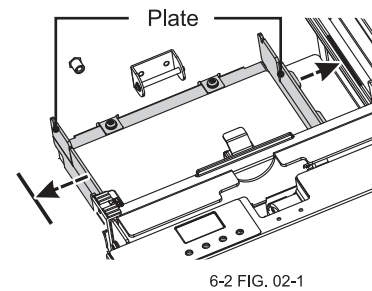

3. After filling into the banknotes, please adjust the plates to close to the wide-size edge of banknotes.

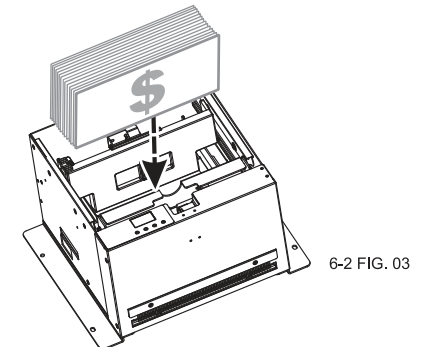

4. Plug in the fixing plate and fasten a screw.

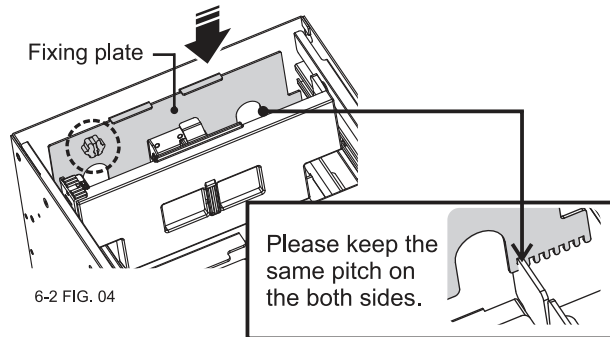

6-3. Low Level Adjustment

To open the cover, you can set up the shreshold of low capacity with the number of 15/35/55.

Ex. Adjust the plate to select “35” of the threshold value, and the display would show **LOB** for low-level alert when banknotes lower than approx.35 notes.

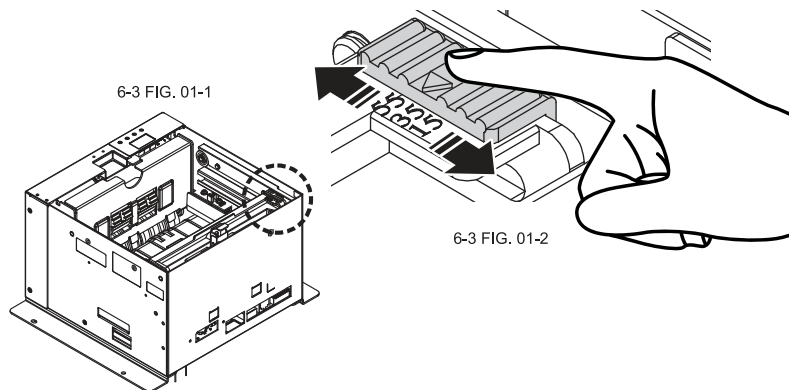

7. Maintenance

To make sure the machine works normally, please be sure to clean up NDE1000 after some period of time.

Please follow the steps below:

1. Unlock the upper cover plate and using the air gun or brush to wipe out the dust inside NDE1000.

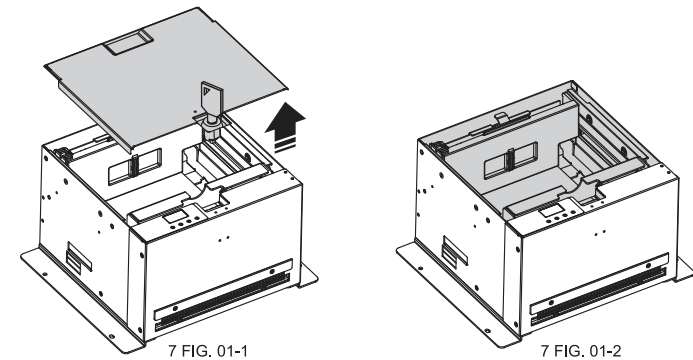

2. Use a screwdriver to loose 5 screws and disassemble the front cover. Be sure to secure the cables connections during cleaning up the device.

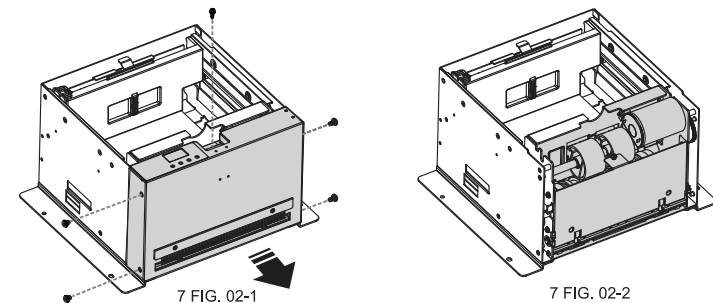

	Maintenance Notice	
	<i>(Any improper maintenance will result invalid warranty.)</i>	
Recommended	Mild, non-abrasive, soap water.	
DO NOT USE	Organic solvent , Alcohol , Volatile liquid.	

8. Troubleshooting

8-1. Error Messages

8-1 TABLE 01

Code	Status	Solution
FrE	Component failure	Contact ICT for help.
AtE		
dAE		
FLE		
LoV	Low voltage	Replace the power supply with standard voltage noted in the specification then the error code will disappear.
HIV	High voltage	
IrE	Sensor problem	Contact ICT for help.
nob	Out of banknote	Please fill in banknotes, and press the Clear key twice then the error code will disappear.
cHA	Banknote(width/length) abnormal	Clean out the dust inside of NDE1000, and press the Clear key twice then the error code cancelled.
db	Double notes	
HAL	Half note	
Jan	Banknote jammed	
Lob	Low level alert	Please add in banknotes.
LrE	Learning error	Make sure there are at least 10 banknotes inside NDE1000, and try the study mode again.
clr	Alert to clean	Please follow step 7 to clean NDE1000, entry setting mode, press the FAC key four times followed by pressing Start key, then the error code cancelled.
doc	Manual dispense exceed max. number recorded (3999 notes)	Keep pressing the Clear key for three seconds and the figure returns to zero.
E01	Motor problem	Contact ICT for help.
E12	Motor problem	



If the error can not be solved after corrective actions or happen again, please contact ICT for technical support.

ict Taiwan

International Currency Technologies Corporation

Ji-Hong Building, No 24, Alley 38, Lane 91, Nei-hu Rd., Sec. 1, Taipei, Taiwan, R.O.C.

Tel: 886-2-2797-1238 · Fax: 886-2-2797-1634

sales@ictgroup.com.tw (For Sales)

rma@ictgroup.com.tw (For Customer Service)

Website: www.ictgroup.com.tw