



# Manual Book

## Flap barrier gate

TS-RNH3088



## **【Foreword】**

Welcome you use our company product, hoping can bring convenient for you when you install the equipment by this manual. If you find any unclear.mistake .lengthiness , please contact our agency or after service department.

◆ This equipment only can install & maintain by qualified serviceman;

◆ Please read this manual careful before you install & use the equipment.

◆ Forbid spread this manual content when don't get our permission.

◆ This manual only provide related information, we will not inform you when some information are changed.

## **【Technical support】**

If you have any questions about the equipment functions & installation, and you also can't get help from this manual, meanwhile in order to avoid damage for the equipment because of setting up error or improper operation, please contact our company to get assist.



---

**This Manual is suit for all of our company's Flap barrier gate.**



# Catalogue

Manual Book .....	0
Flap barrier gate .....	0
1.Product introduce .....	1 -
1.1 Equipment brief Introduction .....	1 -
1.2.Functions & Features .....	1 -
1.3 Standard Technical Parameters .....	3 -
2. Installation Instructions .....	4 -
2.1 Construction and Installation .....	4 -
2.2 Turnstile Communication wiring diagram .....	7 -
2.3 Opening signal & Wiring diagram .....	7 -
3.Commissioning Instructions .....	9 -
3.1.Checking the wiring .....	9 -
3.2.Function debugging .....	9 -
3.3.Working after connect electricity .....	10 -
4.Turnstile control board Instruction book .....	11 -
4.1 Setting parameter table .....	12 -
5.Communication protocol .....	19 -
5.1.hardware protocol .....	20 -



---

1. Write bit operation format (0x05) .....	20 -
5.Fault code definition .....	23 -
6.Common problems & solution.....	24 -
7. Anti-collision swing gate motherboard wiring diagram.....	26 -

# **1.Product introduce**

## **1.1 Equipment brief Introduction**

Swing turnstile is a high-tech product which mainly provides intelligent management to passageway. this product is finely processed with complete functions and high level, suitable for high-level security place, such as, prison, factory , hotel, subway, and port ,etc.

This equipment is subtly integrated with machine, electronics, micro-processor control and ID identification, provides convenience for the use of card reader identification equipment, such as IC card, ID card, bar code and fingerprint. It can carry out intelligent control and management to the passageway through choosing various identification equipment and adopting fair, reliable security protection, alarming equipment and direction indicating equipment...

## **1.2.Functions & Features**

### **1.2.1 Standard functions**

1. with a zero-bit self-inspection function, easy for users to maintain and use.
2. through the built-in small press plate on the control board, the operating state of the programmable device.
3. this type of swing for the new clutch DC brushless motor rotation movement.
4. CNC encoder limit, accurate, efficient, low failure rate.
5. illegal entry, tail alarm, reverse entry gate automatically closed(pedestrian procedure).
6. anti-collision function, when the opening signal is not received, swing swing arm 20 degrees angle, swing arm automatically locked.
7. swing arm synchronous adjustable(for double pendulum situation).
8. with an automatic reset function, after the gate is opened, the system will automatically cancel the pedestrian's access rights during the specified time. The reset time is 1S ~ 60S adjustable(the system default time is 10S). After the power off, the swing arm is freely pushed(in accordance with the fire protection requirements) and the power channel is automatically closed.
- 9.infrared induction reset, infrared induction anti-clip function(selected 3 pairs -11 pairs of infrared).
- 10.has a standard fire input interface, after receiving the fire signal, the equipment is given priority

11. ultra-bright direction indicator board indicating traffic status.

12. can be connected with access control system, consumer system, electronic ticket system, biometric system, electrostatic tester and other equipment.

13. one-way or two-way control of people in and out, infrared sensing into and out of the channel.

14. can be directly through the management of computer remote control and management.

### 1.3 Standard Technical Parameters

Housing Material:	304 stainless steel
Size:	L1400*W300*H1000M
Swing arm length:	250/425mm
Swing direction:	one-way or two-way
Operating voltage:	AC220 $\pm$ 10% V/50 $\pm$ 10% HZ 50W
Drive motor:	DC24V DC brushless motor
Input interface:	Relay dry contact signal or 12V pulse signal with pulse width $\geq$ 100ms, drive current $\geq$ 10mA
Communication interface:	RS232 MODBUS protocol
Passing speed:	40 people / minute (normally open), 25-30 people / minute (normally closed)



Gate opening and closing time:	1-2 seconds
Time required to enter the traffic state after power-on:	3 seconds
Automatic reset time after failure:	10 seconds
Working 13.environment:	indoor, outdoor (shade)
Temperature:	-10 ° C ~ 50 ° C Relative humidity: ≤ 90%, no condensation

## 2. Installation Instructions

### 2.1 Construction and Installation

Firstly , please pre-buried 1 line RVVP3\*1.0 single phase AC220V power line on turnstile’s bottom .between the each passage, please laying 1 line(RVVP8\*0.5) for the 2 pcs turnstile, **please attention** if the card reader and the access control board install in different turnstile,please pre-buried 1 line (RVVP5\*0.5) for access control board with card reader.

Please use setscrews to fixed turnstile on safety island according the following installation size(the details installation as following ): unit mm

## Turnstile Installation Position(1)

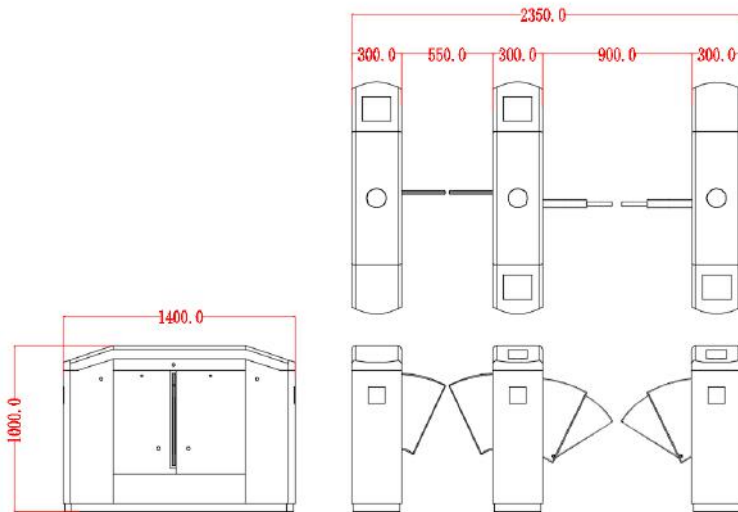

## Turnstile Installation Position(2)

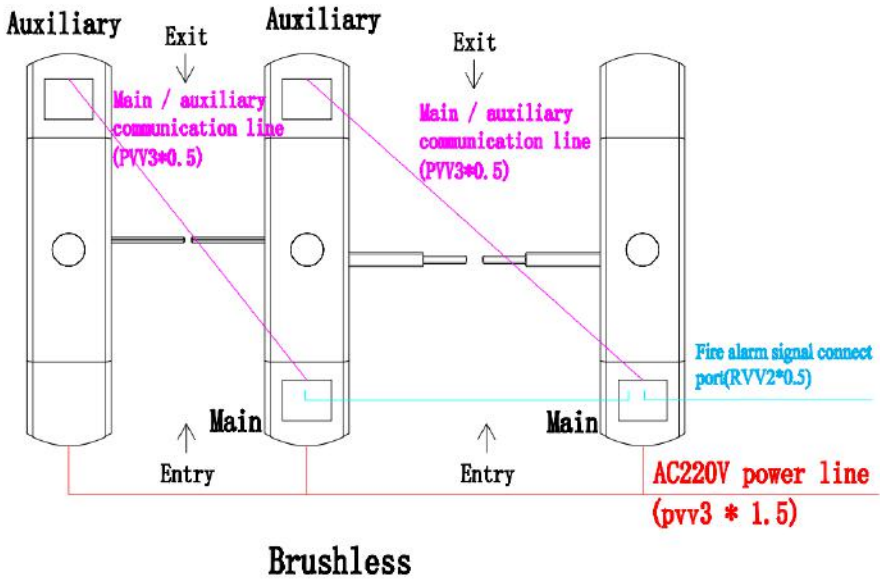

Single passage / double passage line pipe figure

### Note:

**Remark:** The RVVP3\*0.5 cable and access control cable are laid on the communication line. Note that the card reader and the access control are not in the same device. You need to lay a line connecting the RVVP5\*0.5 card reader to the access panel. RVV3\*1.5 power cable is laid on the AC220V power cable.

## 2.2 Turnstile Communication wiring diagram

Synchronization line: TX RX GND. TX and Rx of main and auxiliary machines need to be cross connected

## 2.3 Opening signal & Wiring diagram

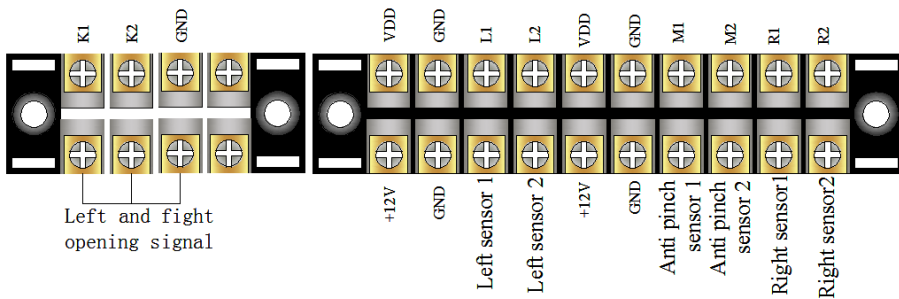

① Input Interface: +12V Level signal or pulse width

≥100ms'DC12V pulse signal, drive current >10mA or Dry contact signal or RS485 signal;

② Way of wiring : Please connect power & open turnstile signal by wiring diagram

A.Dry contact signal: GND is common port, K1 & K2connect with GND respectively are K1 signal and K2 signal;

B.+12VLevel signal or DC12V pulse signal : GND is common port, OPE-L & OPE-R connect with GND respectively are OPE-L signal and OPE-R signal (attention: high frequency connect with OPE-L or OPE-R );

C. Main / auxiliary communication line: the host Rx is connected to the auxiliary TX, the host TX is connected to the auxiliary Rx, and GND corresponds to GND (as shown in the figure);

③ Please checking whether connecting line is same with wiring diagram, please checking whether all of the plugs are well ; please checking whether the equipment are reliable grounding; if all are correct, you can debugging after connect power.

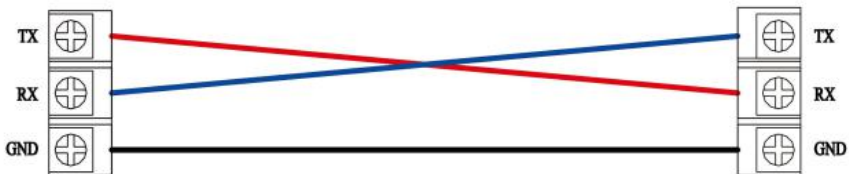

#### 4 Matters need attention

① Without permission, please don't add other peripheral

---

equipments to make sure turnstile safe and reliable.

② When turnstile use in outside, please add 100mm~200mm height Cement platform on the installation place for dampproof, please also add sunshade to protect from the rain, strictly prohibit install the turnstile on outdoor environment directly.

### **3.Commissioning Instructions**

#### **3.1.Checking the wiring**

Please checking whether connecting line is same with wiring diagram, please checking whether all of the wiring are correct, after confirm no problems , you connect power to debugging

please make sure the equipment are reliable grounding, unless you can't do debugging.

#### **3.2.Function debugging**

①Connect urnstile signal.

②Without open turnstile signal, System will trigger alarm When pedestrian enter to turnstile, while without open turnstile signal ,

---

System will trigger alarm When pedestrian exit to turnstile(you can extend the voice prompt ).

③Pedestrian swiping card to pass: after swiping card, the directional indicator will turn green, during the specified time (menu P3 value) pedestrian passed, turnstile will closed, and the green arrow will become red prohibited mark. If during the specified time (menu P3 value) pedestrian still not pass, turnstile will closed, and the green arrow will become red prohibited mark.

④If two pedestrians are too close to pass the turnstile during the specified time, system will treat as 1 pedestrian to pass.

⑤The turnstile open/closed time can adjust, detail information please consult main control board parameter setup instructions.

### **3.3.Working after connect electricity**

Normally Closed flap turnstile model: after connect electricity turnstile closed automatically , when lose electricity it is open automatically.



Normally Open flap turnstile model: after connect electricity





turnstile open

automatically , it is normally open status.

## 4. Turnstile control board Instruction book

**Step 1:** long press the "SET" button until "000" appears, the first "0" flashes.

**Step 2:** Press the “” button to enter the current flashing number. When the number reaches 9, it will automatically return to 0. Press the “” button to change the current flashing digit position. After entering the password "168" in this operation, press the "SET" button once to enter the setting menu, and the current display "F00"

**Step 3:** Press the “” or “” key to move the menu item, move to the menu item to be modified, press “SET” to enter the corresponding menu parameter, press “” or “” to modify the parameter. After completion, Press the “SET” button once to return to the menu item.

**Step 4:** After setting all the parameters, press and hold the “SET” button to return to the initial state (working Status), the modified parameters are automatically saved.

### Password table:

Setting parameters: User technician debugging 168 | Calibration zero point: 605 |



Restore factory value: 999 | Aging movement: 222 (master effective) Wing gate closing point correction: 605, opening point correction 606, power-on steering is closing direction.

## 4.1 Setting parameter table

Menu number	Set range/default	Parameter Description	Notes
F00	0~1(0)	Host or slave selection 0: Host 1: Slave	The host must be connected to the receiving end of the infrared sensor
F01	0~3 (1)	Model selection 0: Tripod turnstile gate; 1: swing gate; 2: 90degree revolving door; 3: flap barrier gate; 4: 120 degree revolving door	
F02	10%~100%(100%)	Motor speed setting	When there is no F36 item, the speed of the Tripod turnstile gate is connected
F03	1~200(1)S	Clutch lock time setting	



F04	0~1 (0)	Motor steering setting	
F05	50~300 (80)	Motor minimum speed setting	When there is no F36 item, the speed of the tripod turnstile gate is connected
F06	0~500(100)	Flap barrier gate/swing gate /Tripod turnstile gate motor early deceleration zone size setting	
F07	0~50(10)	Flap barrier gate/swing gate closing motor advance deceleration zone size setting	
F08	0~1(0)	When the swing gate is powered down or the fire signal is valid, the direction of the door opening is set.	
F09	5~250S(10S)	Valid signal timeout setting	All valid signals will be cleared when the signal times out,just set the host side, the slave does not need to be set
F10	0~1 (0)	Top cover red light running characteristic	Just set the host side,

		<p>setting 0: When the green light is not lit, the red light is on</p> <p>1: When the green light is off, the red light is not lit.</p>	<p>the slave does not need to be set</p>
F11	0~1 (0)	<p>Top cover green light running feature setting</p> <p>0: blinking</p> <p>1: no flashing</p>	<p>If the slave F12 is set to interlock, the setting here can change the side door light switching speed</p>
F12	0~4(0)	<p>Whether the side door light or the three-roller off-pole solenoid is controlled by the on-board ALM relay.</p> <p>0: Side door lights are not controlled by ALM relay</p> <p>1: Side door light ALM relay control, and linkage with K1 signal;</p> <p>2: Side door light ALM relay control, and linkage with K2 signal;</p> <p>3: Side door light ALM relay control, and linkage with K1, K2 signals;</p>	<p>The Tripod turnstile off-pole electromagnet is connected to the ALM relay output terminal to 24V</p>

		4: Three-roller off-rod electromagnet is controlled by ALM relay (default 24V, jumper is 12V)	
F13	0~2(2)	Sensor pairs imported or exported 0: No sensor 1: Connect a pair of sensors; 2: Connect two pairs of sensors;	Just set the host side, the slave does not need to be set
F14	0~1(0)	Free passage in K1 direction 0: Not free passage 1: Free passage	Just set the host side, the slave does not need to be set
F15	0~1(0)	Free passage in K2 direction 0: Not free passage 1: Free passage	Just set the host side, the slave does not need to be set
F16	0~1(0)	Group ticket counting open setting 0: not open 1: open	The overflow value is 65535, just set the host side, the slave does not need to be set
F17	0~1(0)	The switch is normally open and normally closed. 0: Normally closed	Just set the host side, the slave does not need to be set

		1: Normally open Only the wing gate is valid	
F18	0~1(1)	For the first time, the rotary gate has a signal rotation prompt setting 0: no prompt 1: Turn a little hint	
F19	0~1(0)	Wing gate closing positioning lock mode 0: mechanical lock 1: motor reverse push lock	
F20	0~1(0)	Cancel the trailing and trigger the anti-pinch to open the door. 0: Do not open 1: open	Just set the host side, the slave does not need to be set
F21	0~1(1)	Alarm card opening door setting 0: Do not open the door 1: Open the door	Just set the host side, the slave does not need to be set
F22	0~1(0)	Interlock with safety detection device 0: No interlock 1: Interlock	The lock signal is input from the ALM terminal, Just set the host side, the slave does not



			need to be set
F23	0~60(0)S	Delay after closing time setting	Just set the host side, the slave does not need to be set
F24	1~250 (1)	Host computer communication address setting	Just set the host side, the slave does not need to be set
F25	0~4(3)	Host computer communication baud rate setting 0: 1200dps 1: 2400dps 2: 4800dps 3: 9600dps 4: 19200dps	Just set the host side, the slave does not need to be set
F26	0~1(0)	Cancel three-way infrared (F13 set 1) swing gate into alarm and trailing alarm	Just set the host side, the slave does not need to be set
F27	0~10(0)	Swing arm (wing door) bounces after hitting people 0: not open 1-10: open (the bigger the number, the more sensitive)	
F28	2~20(6)	Swing gate closing	



		position allowable deviation value	
F29	0~1(0)	Illegal blocking mode setting 0: Clutch 1: Motor reversal torque	
F30	0~10(3)	Motor reverse torque setting when illegally blocked	
F31	0~1(1)	Spare	
F32	0~4(1)	Gate switch door deceleration intensity setting 1: softest 4: fastest	
F33	50~600 (100)	Swing gate opening angle setting (the larger the number, the larger the opening angle)	
F34	0~1(0)	Whether the swing gate trails and reverses back to close the door. 0: No off 1: Off	Please note that there may be a risk of hitting people and use them with caution!
F35	0~1(0)	The gate state of the gate is illegally pushed (rod)	



		clutch lock style 0: anti-squeeze style 1: tightly blocked style	
F36	50~500(150)	Gate power-on speed setting	No version of this setting sets the power-on speed through F02 and F05.
F37	0~3(0)	0~3(0) Voice function control 0: Off 1~3: Turn on voice mode 1~3	Only support the company's voice board, see the voice board description
F38	10~99 (99)	Speed setting of the wing (swing arm) when the gate is powered down	
F39	0~1(0)	After the F27 is turned on, the swinging arm swings to the person to deal with the way. Fixed pop-up mode 0: Stop 1: Bounce	

## 5.Communication protocol

---

## 5.1. hardware protocol

Communication signal: RS232,

Communication baud rate: parameter F25 setting

Start bit: 1 bit

Stop bit: 1 bit

Data bit length: 8-bit data bit

Parity: None

## 5.2. The frame protocol

The host computer uses the standard MODBUS-RTU for communication, the communication address is set by F06, and the baud rate is set by F07. The communication format is as follows:

### 1. Write bit operation format (0x05)

Communication address + command (0x05) + start address high byte + start address low byte + set / reset (0xFF / 0x00) + 0x00 + CRC low + CRC high.

Return data: same as above

Address corresponding signal

0x0000 alarm signal (ALM)

---

0x0001 Fire Signal (XF)

0x0002 Clear the number of K1 direction signals

0x0003 Clear the number of K2 direction signals

0x0004 Clear K1 direction counter data

0x0005 Clear K2 direction counter data

0x0006 Free passage in K1 direction

0x0007 Free passage in K2 direction

0x0008 Gate open setting

Example: set alarm signal 01 05 00 00 FF 00 8C 3A

Clear alarm signal 01 05 00 00 00 00 CD CA

Set fire signal 01 05 00 01 FF 00 DD FA

Fire fighting signal 01 05 00 01 00 00 9C 0A

Clear K1 signal number 01 05 00 02 FF 00 2D FA

Clear K2 signal number 01 05 00 03 FF 00 7C 3A

Clear K1 counter data 01 05 00 04 FF 00 CD FB

Clear K2 counter data 01 05 00 05 FF 00 9C 3B

Set the free passage in the K1 direction 01 05 00 06 FF 00 6C 3B

Cancel free passage in K1 direction 01 05 00 06 00 00 2D CB

Set K2 direction free passage 01 05 00 07 FF 00 3D FB

Cancel free passage in K2 direction 01 05 00 07 00 00 7C 0B

Set the gate to open normally 01 05 00 08 FF 00 0D F8

Cancel the setting of the gate normally open 01 05 00 08 00 00 4C

**\*Notes:** Free pass is set here. The normally open and canceled gates will not be saved and will be cleared after power off. If it is set in the menu, it cannot be canceled here, and the setting in the menu takes precedence.

## 2. Write a single register operation format (0x06)

Communication address + command (0x10) + start address high byte + start address low byte + data high byte + data low byte + CRC low + CRC high.

Return data: Same as above

Address	corresponding signal
0x0000	K1 direction number of people
0x0001	K2 direction number of people

Example: K1 direction setting 1 01 06 00 00 00 01 48 0A

K2 direction setting 1 01 06 00 01 00 01 19 CA

## 3. Read multiple register operation formats (0x03)

Communication address + command + start address high byte + start address low byte + number to read high byte + number to read low byte + CRC low + CRC high.

Return data: communication address + command + number of

returned data bytes + data 1 high byte + data 1 low byte + . . . +CRC  
high + CRC low.

Address	corresponding signal
0x0000	K1 direction number of people
0x0001	K2 direction number of people

Example: K1 direction setting 01 03 00 24 00 01 C4 01

K2 direction setting 01 03 00 26 00 01 65 C1

At the same time, read the total number of people in K1 and K2  
directions: 01 03 00 24 00 02 84 00

#### 4. Read multiple switch signal operation formats (0x01)

Communication address + command + start address high byte + start  
address low byte + number to read high byte + number to read low byte  
+ CRC low + CRC high.

Return data: communication address + command + number of  
returned data bytes + data 1 high byte + data 1 low byte + . . . +CRC  
high + CRC low.

Address	Corresponding signal
0x0050	fault signal

Only 16 switching commands can be read at a time: 01 01 00 50 00  
10 3D D7

#### 5. Fault code definition

Bi t0	Motor overcurrent
Bi t1	12V power failure
Bi t2	Motor stall
Bi t3	Illegal push rod
Bi t4	
Bi t5	K1 direction trailing
Bi t6	K2 direction trailing
Bi t7	K1 direction reverse
Bi t8	K2 direction reverse
Bi t9	Blocking the intermediate sensor for a long time
Bi t10	Block K1 exit for a long time
Bi t11	Block K2 exit for a long time
Bi t12	Input voltage is too high
Bi t13	
Bi t14	
Bi t15	Open states

## 6.Common problems & solution

---

When the following fault occurs in the system, the digital tube displays the following fault code, and sending a signal to either side of K1 or K2 will clear the fault.

- E01: Motor overcurrent
- E02: DC 12V output overcurrent protection
- E03: Motor stall
- E04: Illegal push rod
- E05: Input illegal signal
- E06: Trailing in the K1 direction
- E07: Trailing in K2 direction
- E08: Reverse direction in K1 direction
- E09: K2 direction reverse
- E10: Do not walk in the middle for a long time
- E11: Do not stand at K1 exit for a long time
- E12: Do not stand at K2 exit for a long time
- E13: External input voltage is too high

## **7. Anti-collision swing gate motherboard wiring diagram**

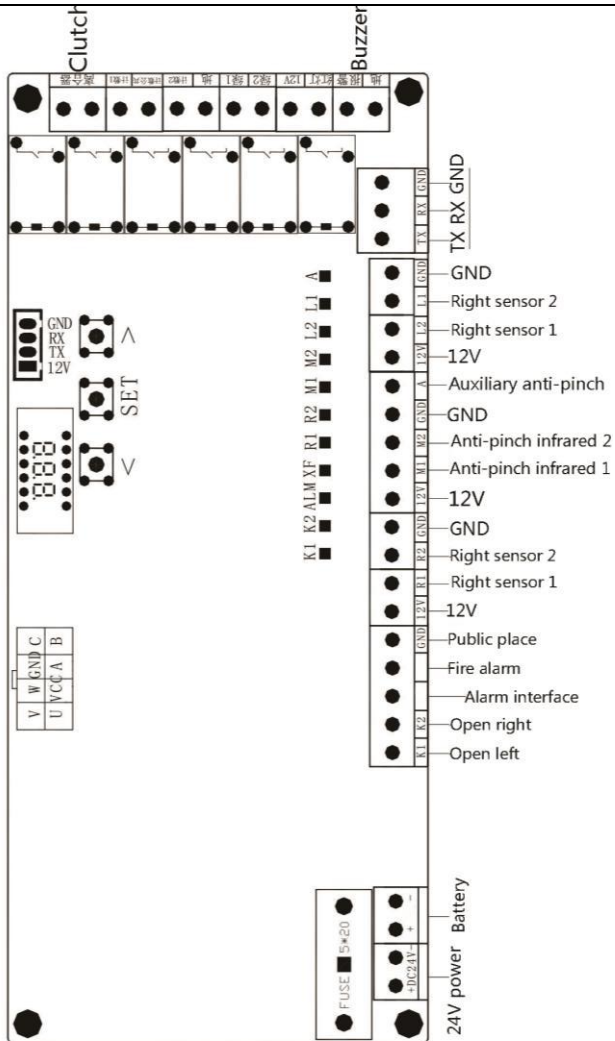

The company reserves the right to modify the use of the materials without notifying the customer. The new product specifications will be based on the latest version of the data